



5010

INSTALLATION AND OPERATING INSTRUCTIONS

IF YOU CANNOT READ OR UNDERSTAND THESE INSTALLATION INSTRUCTIONS DO NOT ATTEMPT TO INSTALL OR OPERATE

INTRODUCTION

This SKYTECH remote control system was developed to provide a safe, reliable, and user-friendly remote control system for gas heating appliances. The system can be operated manually from the transmitter. The system operates on radio frequencies (RF) within a 20' range using non-directional signals. The system operates one of 1,048,576 security codes that are programmed into the transmitter at the factory; the remote receiver's code must be matched to that of the transmitter prior to initial use.

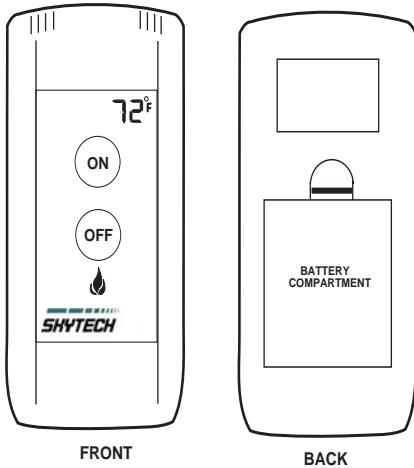

The transmitter operates on 4 AAA-size 1.5V batteries. It is recommended that ALKALINE batteries always be used for longer battery life and maximum operational performance. **IMPORTANT:** New or fully charged batteries are essential for proper operation of the multi-function transmitter. Insert 4 AAA-size 1.5 V batteries into the battery compartment on the back of the transmitter, positioning the (+) and (-) ends of the batteries as indicated on the casing. When the batteries are inserted, the screen at right (with similar numbers) will display.

Note: On initial start up if a LOW battery icon appears on the screen, check the position of the batteries.

Note: Due to the sensitive temperature-monitoring components in the transmitter, it may be necessary to allow the transmitter to stabilize to room temperature before accurate room temperatures are displayed on the screen. If the transmitter is activated from a severe cold condition, it can take up to fifteen minutes for accurate temperature readings to appear.

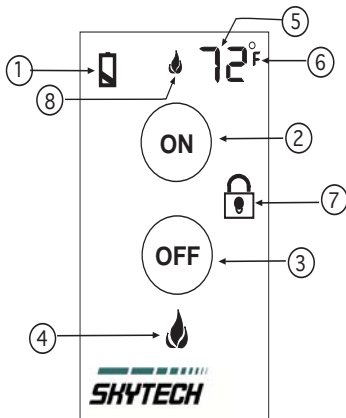
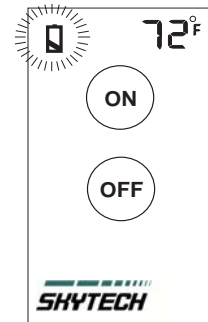

1. **BATTERY ICON** - Battery power is low. Replace batteries within two weeks.
2. **ON-** Indicates the appliance is ON – Flame Icon
3. **OFF-** Indicates the appliance is OFF – NO Flame Icon
4. **FLAME** – Indicates burner/valve in operation.
5. **ROOM** – Indicates CURRENT room temperature.
6. **° F** indicates degrees Fahrenheit (**°C** indicates degrees Celsius).
7. **LOCK – Child lock out.**
8. **RF SIGNAL ICON** –Appears when the RF signal is being transmitted.

OPERATION FUNCTIONS

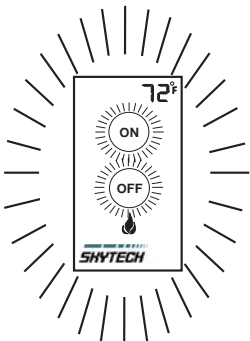

1. Touch anyplace on the screen and the screens blue back light will light up and stay on for (5) seconds.
2. Touch the ON button on the LCD screen front of the transmitter to turn the appliance ON.
3. Touch the OFF button on the LCD screen front of the transmitter to turn the appliance OFF.

SETTING ° F / ° C SCALE

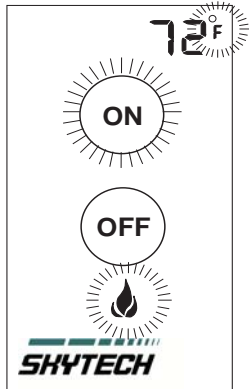

The factory setting for temperature is ° F. To change this setting to ° C, first press and hold the ON button and the FLAME ICON on the transmitter LCD screen at the same time for (5) seconds. Follow this same procedure to change from ° C back to ° F.

CHILDPROOF “LOCK-OUT”

This remote control includes a CHILDPROOF “LOCK-OUT” feature that allows the user to “LOCK-OUT” operation of the appliance from the TRANSMITTER when it is in the “LOCK OUT” mode.

SETTING “LOCK-OUT”

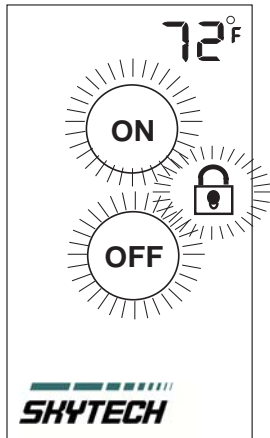

1. To activate the “LOCK-OUT” feature, press and hold the ON and OFF icons on the LCD screen together, for 5 seconds. The lock icon will appear on the LCD screen.
2. To disengage the “LOCK-OUT”, press and hold the ON and OFF icons on the LCD screen together, for 5 seconds. The lock icon will disappear on the LCD screen and the system will return to its normal operating condition.

NOTE: If the appliance is already operating in the ON mode engaging the “LOCK-OUT” will not cancel the operating MODE. Engaging the “LOCK-OUT” prevents only the manual operation of the TRANSMITTER

RECEIVER

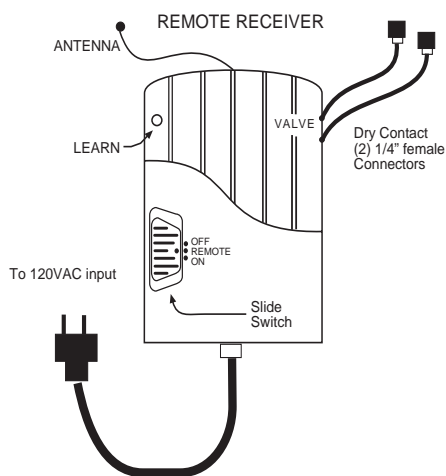

When plugged into a standard 110-120 VAC receptacle, the remote receiver operates on commands from the transmitter or from the slide switch on the top of the receiver (This switch is to be used during a power outage to operate the appliance manually). The remote receiver is manufactured with a “dry contact” relay in its circuitry that operates like an on/off switch, however, no power or current passes from the 110-120 VAC input side to the wires leading from the output side of the remote receiver.

This 5010 remote control system can be used in simplified installations to control a millivolt gas valve without any additional relays or components.

LOCATING THE RECEIVER

PROTECTION FROM EXTREME HEAT IS VERY IMPORTANT. Like any piece of electronic equipment, the remote receiver should be kept away from temperatures exceeding 130° F. Exposure to extreme temperatures can damage the electronic components or cause the plastic case to become deformed and is not covered under warranty.

WARNING

THIS REMOTE CONTROL SYSTEM MUST BE INSTALLED EXACTLY AS OUTLINED IN THESE INSTRUCTIONS. READ ALL INSTRUCTIONS COMPLETELY BEFORE ATTEMPTING INSTALLATION. FOLLOW INSTRUCTIONS CAREFULLY DURING INSTALLATION. ANY MODIFICATION OF THIS REMOTE CONTROL OR ANY OF ITS COMPONENTS WILL VOID THE WARRANTY AND MAY POSE A FIRE HAZARD.

WIRING INSTRUCTIONS

A qualified electrician or a gas technician who is familiar with the gas appliance and gas valves that will be operated by this remote should install the remote control system. Incorrect wiring connections **WILL** cause damage to the gas valve or electronic module operating the gas appliance and may also damage the remote receiver.

WIRING MILLIVOLT VALVES

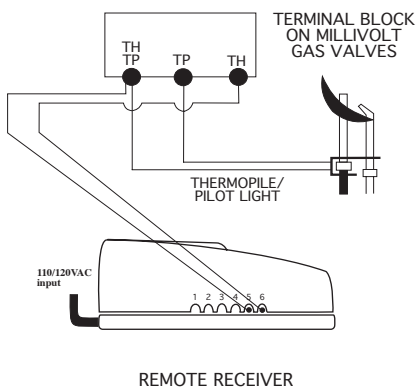

The remote receiver is to be connected to the millivolt valve.

Connect one of the (2) 18 gauge wires from the 5010 receiver to the TH terminal and the other to the THTP terminal on the terminal block on the millivolt gas valve.

Operation of the remote receiver is similar to that of a thermostat in that both turn the gas valve on and off based on input signals. A thermostat's input signals are different temperatures. The remote receiver's input signals come from the transmitter.

WIRING ELECTRONIC SPARK IGNITIONS

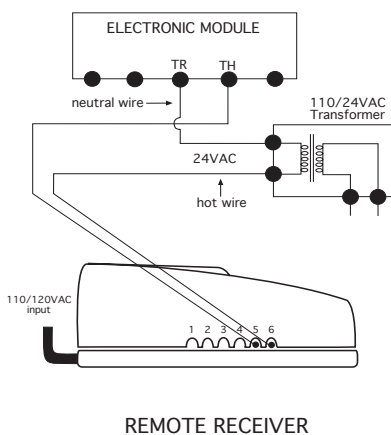

Most electronic systems operate on a 110-120 VAC/24VAC power transformer used to power the system electronic ignition module and electronic gas valve, which can be controlled by the 5310 remote receivers as, illustrated.

NOTE: THE 110-120 VAC/24VAC, transformer may be purchased from your appliance dealer, or an electronic parts distributor.

The remote control receiver can be connected, in series, to a 24VAC transformer to the TR (transformer) terminal on the ELECTRONIC MODULE. Connect the hot wire from the 24VAC transformer to either of the wires on the remote receiver. Connect the other wire from the receiver to the TH (thermostat) terminal on the ELECTRONIC MODULE.

SYSTEM CHECK

MILLIVOLT VALVES

Light your gas appliance following the lighting instructions that came with the appliance. Confirm that the pilot flame is on; it must be in operation for the main gas valve to operate.

- Slide the 3-position button on the remote receiver to the ON position. The main gas flame (i.e., the fire) should ignite.
- Slide the button to OFF. The flame should extinguish (the pilot flame will remain on).
- Slide the button to REMOTE (the center position) then press the ON button on the transmitter to change the system to ON. The main gas flame should ignite.

ELECTRONIC IGNITION SYSTEMS

- Slide the 3-position button on the remote receiver to the ON position. The spark electrode should begin sparking to ignite the pilot (the pilot may ignite after only one spark). After the pilot flame is lit, the main gas valve should open and the main gas flame should ignite.
- Slide the button to OFF. The main gas flame and pilot flame should BOTH extinguish.
- Slide the button to REMOTE (the center position), and then press the ON button on the transmitter to change the system to ON. The spark electrode should begin sparking to ignite the pilot. After the pilot is lit, the main gas valve should open and the main gas flame should ignite.

PROTECTION FROM EXTREME HEAT IS VERY IMPORTANT. Like any piece of electronic equipment, the remote receiver should be kept away from temperatures exceeding 130⁰ F. Exposure to extreme temperatures can damage the electronic components or cause the plastic case to become deformed and is not covered under warranty.

GENERAL INFORMATION

MATCHING SECURITY CODES

Each transmitter can use one of 1,048,576 unique security codes. It may be necessary to program the remote receiver to LEARN the security code of the transmitter upon initial use, if batteries are replaced, or if a replacement transmitter is purchased from your dealer or the factory. When matching security codes, be sure slide button on the receiver is in the REMOTE position; the code will NOT "LEARN" if the slide switch is in the ON or OFF position. Program the remote receiver to LEARN a new security code **Push and Release** the LEARN button on the front of the remote receiver and then **Press** any button on the transmitter. A change in the beeping pattern, at the receiver, indicates the transmitter's code has been programmed into the receiver. When an existing receiver is matched to a new transmitter, the new security code will override the old one.

The microprocessor that controls the security code matching procedure is controlled by a timing function. If you are unsuccessful in matching the security code on the first attempt, wait 1-2 minutes before trying again – this delay allows the microprocessor to reset its timer circuitry – and try up to two or three more times.

BATTERY LIFE

Life expectancy of alkaline batteries in the SKYTECH 5010 should be at least 12 months. Check and replace all batteries annually. When the Transmitter no longer operates the receiver from a distance it did previously (i.e., the transmitter's range has decreased) or the remote receiver does not function at all, the transmitter batteries should be checked. The Transmitter should operate with as little as 5.0 volts of battery power, measuring at the (4) 1.5-volt batteries.

TROUBLE SHOOTING

Should you encounter problems with your fireplace system, the problem may be with the fireplace itself or it could be with the SKYTECH remote control. Review the fireplace manufacturer's operation manual to make sure all connections are properly made. Then check the operation of the SKYTECH remote in the following manner:

1. Be sure the transmitter's batteries are properly installed and that the battery output is 5.0 V or more.
2. Check to see if the receiver is connected to a 110-120 VAC power source.
3. Check to make sure the transmitter is communicating with the receiver.

- If the receiver beeps when the MODE button is depressed on the transmitter they are communicating.
 - If the receiver does not beep when the MODE/SET button is depressed on the transmitter, you will need to teach the receiver the code of the transmitter. This is done by PRESS AND REALEASE the LEARN button on the receiver and depress the MODE/SET button on the transmitter. A change in the beeping pattern, at the receiver indicates the transmitter's code has been programmed into the receiver.
4. Make sure the transmitter is within the 15'-20' range of the receiver.
 5. Positioning of the receiver is important. If the receiver is "enclosed" in a metal surround, the operation of the receiver may be affected as noted below. Reposition the receiver to improve operating range. It is suggested that a heat shield be installed to protect the receiver from extreme heat. If the receiver is "enclosed" in a metal surround, this can:
 - Cause the RF signal to get lost and not communicate with the receiver.
 - Cause the working distance to be shorter than normal.

NOTE: A receiver located in an area, where the ambient temperature inside the case exceeds 130 °F, will cause THERMO-SAFETY feature to cut in, requiring you to reposition the receiver to stop the warning beeps, and to "reset" the receiver's operation.

SPECIFICATIONS

BATTERIES: Transmitter 6V –4ea. AAA 1.5 Alkaline
 Remote Receiver 110-120 VAC
 Operating Frequency: 303.875MHZ

FCC ID No.'s: transmitter –K(L5001; receiver – K9L1410RX
 Canadian ISC ID No.'s: transmitter –2439A-5001; receiver – 2439A-1410RX

FCC REQUIREMENTS

NOTE: THE MANUFACTURER IS NOT RESPONSIBLE FOR ANY RADIO OR TV INTERFERENCE CAUSED BY UNAUTHORIZED MODIFICATIONS TO THIS EQUIPMENT. SUCH MODIFICATIONS COULD VOID THE USER'S AUTHORITY TO OPERATE THE EQUIPMENT.

FOR TECHNICAL
 SERVICE, CALL:

U.S. INQUIRIES
 888/672-8929 or
 260/459-1703
 Website: skytechsystem.com

CANADIAN INQUIRIES
 877/472-3923

MANUFACTURED EXCLUSIVELY FOR SKYTECH II, INC

Limited Lifetime Warranty

SKYTECH II warrants the SKYTECH REMOTE CONTROL SYSTEM for a Limited Lifetime of the original owner of this system. This warranty is not transferable to another person it is for the original purchaser of the product. Should any part fail because of defective workmanship or material from the original date of purchase. SKYTECH II will repair or, at SKYTECH II option, replace the defective parts.

Replacement parts will be available at no charge for the first (5) five years of this warranty, and will be available at market cost for the Lifetime of the product to that original owner. If SKYTECH II does not have the parts for an individual model, then a replacement SYSTEM will be provided. At no charge for the first (5) five years and sold at market cost for the Lifetime of that product to the original owner.

The Owner must provide a bill of sale, cancelled check, or payment record should be kept to verify purchase date and establish warranty period. Travel, diagnostic cost, service labor to repair the defective SYSTEM, and freight charges on warranty parts to and from the factory will be the responsibility of the owner. SKYTECH will not be responsible for labor charges and/or damage incurred in installation, repair, replacement, or for incidental or consequential damages. Batteries and any damage caused by them are not covered by them are not covered by this warranty.

This warranty does not cover claims, which do not involve defective workmanship or materials.

Damage to the SYSTEM caused by accident, misuse, abuse, or installation error, whether performed by a contractor, Service Company, or owner, is not covered by this warranty. Modification of the SKYTECH product will void this warranty.

IN NO EVENT SHALL SKYTECH BE LIABLE FOR INCIDENTAL AND CONSEQUENTIAL INCLUDING THE IMPLIED WARRANTIES OF MERCHANTABILITY AND FITNESS, ARE LIMITED TO THE DURATION OF THIS WRITTEN WARRANTY. THIS WARRANTY SUPERSEDES ALL OTHER ORAL OR WRITTEN WARRANTIES.

Some States do not allow the exclusion or limitation of incidental and consequential damages or limitation on how long an implied warranty lasts, so the above limitation may not apply to you. This warranty gives you specific rights and you may have other rights, which vary from state, province, and nation.

How to Obtain Service:

Contact SKYTECH II or your SKYTECH Dealer direct with the following information:

- Name, Address, Telephone Number of Owner
- Date of Purchase, Proof of Purchase
- Model Name, Date Code
- Any relevant information or circumstances, e.g., installation, mode of operation when defect was noted.

Warranty claim process will start with all of this information. SKYTECH will reserve the right to physically inspect the product for defects, by authorized representatives.

Detach at this line for return to: Skytech II 9230 Conservation Way, Fort Wayne, IN 46809 Telephone: (888) 672-8929
Purchase Date: _____ Model: _____ Date Code: _____

Purchased From: _____ Date: _____
Customer Name _____ Number of Santa's Helpers _____

Address _____

City _____ State/Prov. _____ Zip/Postal Code _____

Credit Card Number _____ Expiring Date _____

(Visa and MasterCard Only) See other side for a special offer for all Remote control Customers

Santa's Helper

Exclusive offer to Skytech Remote Control Owners

This special offer is only provided to customers of Skytech II, Inc. that have purchased a remote control for their Hearth Product. This remote control system can be used for any 110Volt appliance, but perfect your Christmas Tree Lights or any other appliance that is difficult to reach or plug in. Simply plug the receiver into your wall outlet and your appliance into the receiver, push the ON button on the transmitter and you are in business. It's that easy.

Model **1310**



Santa's Helper

Santa's Helper is a unique and specialized device designed to save time and effort. Every Christmas brings the challenge of plugging in the lights on the tree. But this year can be different. Simply plug the remote directly into a standard 110 household electrical outlet and plug your light directly into the receiver. You can even use an extension cord for convenience. Then with a simple push of the button on the transmitter, your lights are turned on and off with ease.

From as far away as 100 feet, the radio frequency controls only what is plugged into the receiver. With over 255 security codes, no other appliances will be affected. And best of all, you don't even have to point the remote at the receiver.

Features:

- 110 VAC - input
- 2 prong polarized plug
- 110 VAC - output
- 2 prong polarized receptacle
- 1000 Watts of rated power or 1/4 HP motor
- Transmitter is battery operated (12 Volt included)
- 255 Security Code
- 100 feet of Operational Distance
- All Radio Frequency
- UL and FCC Approved

888-672-8929 | 888-672-8024 (FAX)
9230 CONSERVATION WAY | FORT WAYNE, INDIANA 46809

The list price of **\$34.95** for the Santa's Helper has been cut over half to **\$15.00 USD** for this exclusive offer. Shipping and handling of **\$5.00 USD** should be added. Send your check, money order or your Visa / MasterCard number, with Expiration Date to our office, along with the warranty information from your remote control for your Hearth Product. You can send this via mail, fax, or e-mail.

Skytech II, Inc.

9230 Conservation Way
Fort Wayne, IN 46809

1 (888) 672-8929

1 (888) 672-8024 Fax

skytechsystem@fwin.net e-mail